

**Quick Release Arbor** VOL.2



**MULTIFITBLADES**  
oscillating tool blades and accessories



MultiFitBlades.com  
1-888-594-4442

## Quick Release Arbor

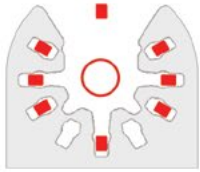

DeWalt®

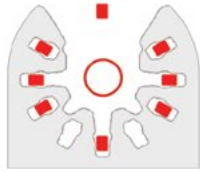

New Porter Cable®



Rockwell® Sonicrafter®  
Hyperlock



Worx® Sonicrafter®  
Hyperlock



Porter Cable®  
Original



Fein®  
Multimaster™



Bosch® Multi-X™  
(tool-free models  
require cclip adaptor)  
Makita®  
Milwaukee®

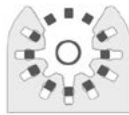

Dremel® Multi-Max™  
(tool-free models  
require cclip adaptor)

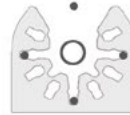

Chicago  
Electric®

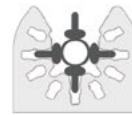

Craftsman®



Rigid®  
Jobmax™



### Quick Release oscillating blades and accessories are also compatible with these machines:

Channellock®, Force® 2.2 Amp, Genesis®, GTV® Oscillating Tool, Haussmann® 5-in-1, i-Drill®, Jobmate® Oscillating Tool, Kawasaki®, King Canada®, Klutch®, Kwiktool USA®, Mastercraft®, Master Mechanic®, Performax®, Power IT® Multi-Tool, Project Pro®, Ryobi® JobPlus™, Samona® (Rok) Multi-Tool, Shop Basics®, Skill®, SunZi® Multi-Tool, Task Force®, Tool Shop®

All brands are registered trademarks of their respective owners.

Black & Decker 'Matrix' & Craftsman 'Bolt-On' owners, please be aware that our Quick Release blades will NOT fit the multi-tool component of your cordless machine.

For the **complete compatibility list**, visit [MultiFitBlades.com](http://MultiFitBlades.com) or call 1-888-594-4442.

## More Catalogs from MultiFitBlades

### Multi-Fit Standard Arbor



To **download** the Multi-Fit Standard Arbor, visit [MultiFitBlades.com/catalogs](http://MultiFitBlades.com/catalogs)



## Welcome to the World of Multi-Fit Blades

We are your one stop oscillating tool blade accessory Super-Center.

Multi-Fit Blades is revolutionizing the oscillating tool industry by offering our customers the broadest selection of Low Cost, High Quality replacement blades and accessories for your multifunction power tools.

As oscillating tooling specialists, we are continuously striving to develop new cutters and accessories for your machines. Browse our catalog to see familiar favorites and new product ideas guaranteed to broaden your horizons.



### Contents

page

Machine Compatibility	inside cover
Applications Overview	2
Blades & Accessories	3
Metal Cutting	3
Wood Cutting	5
Tile Grout & Masonry	9
Scraping, Caulking, Flexible Material Cutting	12
Sanding, Cleaning	14
Miscellaneous Parts	17
Kits	18
Tips & Tricks	22
Inventor Program	23



To order visit [MultiFitBlades.com](http://MultiFitBlades.com) or call **1-888-594-4442**

## Applications Overview

Sku	Medium Metal	Thin Metal	Wood with Nails	Clean Wood	Drywall	Plastics	Tile Grout and Masonry	Plaster
Q001	•		•	•	•	•		
Q002		•	•	•	•	•		
Q045		•	•	•	•	•		
Q450T	•	•	•	•	•	•		
Q120T	•	•	•	•	•	•		
Q122	•	•	•	•	•	•		
Q004				•	•	•		
Q004-1TN				•	•	•		
Q5045				•	•	•		
Q009				•	•	•		
Q003				•	•	•		
Q003bi			•	•	•	•		
Q008				•	•	•		
Q008bi			•	•	•	•		
Q006HC				•	•	•		
Q005HC				•	•	•		
Q016							•	•
Q017							•	•
Q064							•	•
Q029							•	•
Q029TN							•	•
Q031							•	•
Q034							•	•

**Metal Cutting p. 3, 4**  
Also cuts Wood with Nails, Clean Wood, Drywall and Plastics.

**Wood Cutting p. 5 - 8**  
Also cuts Drywall and Plastics.

**Tile Grout and Masonry p. 9 - 11**  
Also cuts Plaster.

## 1-3/8" Bi-Metal Universal Quick Release Saw Blade // Q001

Use this general purpose Universal saw blade to cut through nail embedded wood.

- This budget saver universal saw blade is a popular cutter for those who just want one simple blade choice to do it all
- Ideal for remodeling jobs requiring general cutting of nail embedded wood
- Made by laser welding a high speed steel cutting edge to a flexible alloy steel back to resist breaking and extend the durability of this blade



Blade width	Teeth per Inch	Plunge Depth
1-3/8" x 0.035" material thickness	18	1-9/16"

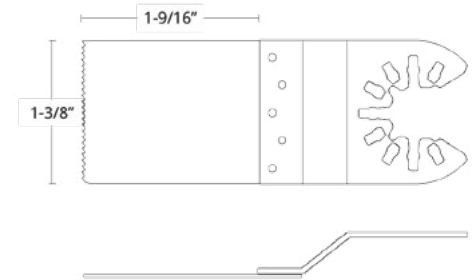

## 1-1/8" Bi-Metal Quick Release Saw Blade // Q002

This general purpose Bi-Metal Universal saw blade has a 2-1/8" long reach for cutting nail embedded wood.

- This premium bi-metal blade is very effective at plunge and linear cutting situations
- Ideal for remodeling jobs requiring general cutting of nail embedded wood
- Made by laser welding a M42 high speed steel cutting edge to a flexible alloy steel back to resist breaking and extend the life of this blade



Blade width	Teeth per Inch	Plunge Depth
1-1/8" x 0.035" material thickness	20	2-1/8"

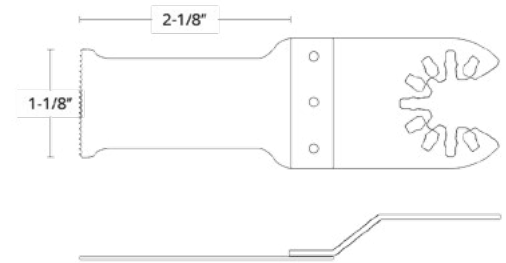

## 1-3/4" Wide Bi-Metal Universal Quick Release Saw Blade // Q045

This wider blade is great for maintaining cutting contact as you saw through nail embedded wood.

- Our 1-3/4 inch wide Universal Bi-Metal Blades are designed for flush or plunge cutting situations
- This extra wide blade makes it easy for new users to maintain proper cutting contact
- Made by laser welding a M42 high speed steel cutting edge to an alloy steel back for a robust saw blade that resists breaking



Blade width	Teeth per Inch	Plunge Depth
1-3/4" x 0.035" material thickness	20	1-5/8"

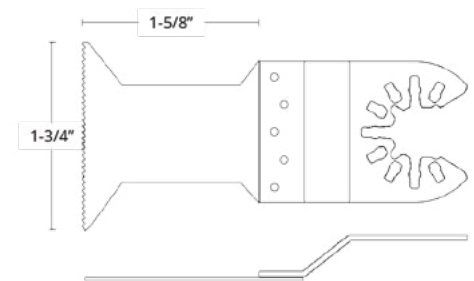

## 1-3/4" Wide Titanium Bi-Metal Universal Quick Release Saw Blade // // // // Q450T

The protective coating of Titanium over the cutting teeth makes this blade ideal for continuous demolition or construction work.

- Choose our Titanium coated bi-metal blades for extended life cutting situations
- The wide width of this blade is ideal for maintaining cutting contact and control as you cut through fiberglass, PVC, copper pipes, metal mesh or sheet metal
- Capable of 2-1/4 inch deep cutting plunges



Blade width	Teeth per Inch	Plunge Depth
1-3/4" x 0.033" material thickness	20	2-1/4"

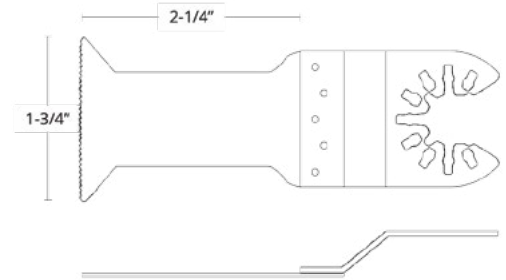

## 4" Segmented Circular Titanium Bi-Metal Quick Release Saw Blade // // // // Q120T

The protective coating of Titanium over the cutting teeth makes this blade ideal for continuous linear cutting of sheet metal, wood and plastic.

- Choose this Titanium coated bi-metal blade for extended service life cutting
- Great for making precise cuts in nail embedded wood or drywall. This blade is also well suited for cutting plastics, copper, tin and aluminum
- Round blades facilitate precise control and stability when making longer span cuts



Blade width	Teeth per Inch	Plunge Depth
4" x 0.030" material thickness	20	1-3/4"

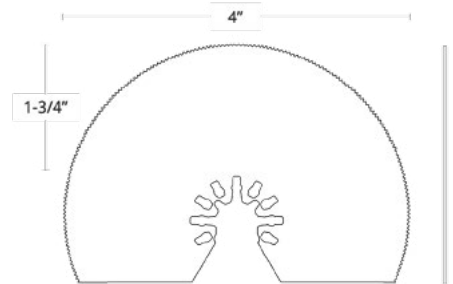

## 4" Flush Cut Segmented Circular Quick Release Saw Blade // // // // // // // // // // Q122

Voted as our **Best all Purpose Cutter**. Use this blade for linear cutting of sheet metal, wood and most plastics.

- Made from M42 high speed steel this blade works as an excellent long life cutter
- The 'flush-cut' center cup design allows this blade to be placed flat on your control surface for precision cutting
- Round blades typically facilitate precise control and stability when making longer span cuts



Blade width	Teeth per Inch	Plunge Depth
4" x 0.030" material thickness	20	1-1/16"

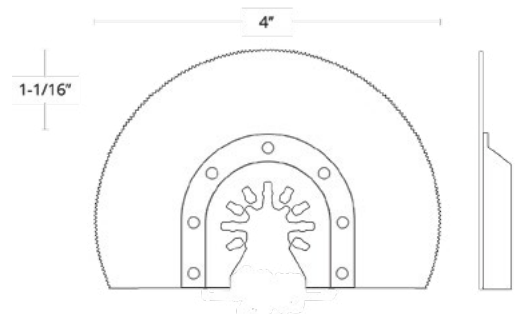

## 1-3/8" Japan Tooth Quick Release Saw Blade // AGGRESSIVE CUTS // Q004

Consider using this saw blade for fast and clean cutting of softer woods such as pine, spruce and fir.

- Precision ground double-row of beveled teeth, allow for fast plunge cuts into wood, sheetrock and soft plastics
- This aggressive blade will have you approaching reciprocating saw cutting speeds
- The sharpened teeth on this blade will cut through laminates without chipping



Blade width	Teeth per Inch	Plunge Depth
1-3/8" x 0.025" material thickness	14	1-9/16"

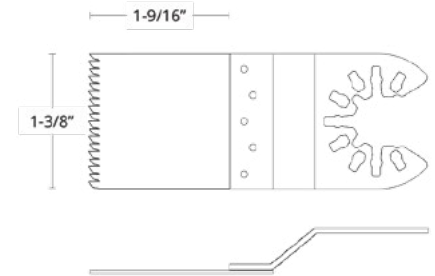

## 1" Japan Tooth Quick Release Saw Blade // AGGRESSIVE CUTS // Q004-1TN

This narrow fast cut blade is excellent for increased plunge precision and control.

- Consider this one inch wide blade for aggressive cuts in tight spaces
- Utilizes a double-row of precision ground beveled teeth for clean cuts
- Great for controlled plunge cuts into softwoods at maximum speeds



Blade width	Teeth per Inch	Plunge Depth
1" x 0.025" material thickness	14	1-9/16"

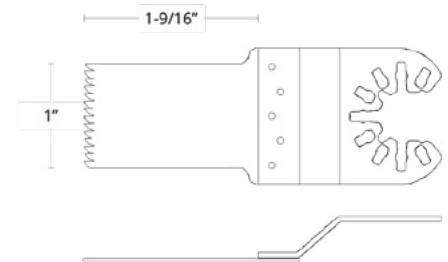

## 1-3/4" Japan Tooth Quick Release Saw Blade // AGGRESSIVE CUTS // Q5045

Use this aggressive wide blade for deeper plunges and faster linear cuts.

- This premium saw blade is made from M42 High Speed Steel for a long service life
- Great for plunge or linear cuts in both soft and hardwoods
- Utilizes a double-row of precision ground alloy steel teeth for extended clean cuts



Blade width	Teeth per Inch	Plunge Depth
1-3/4" x 0.035" material thickness	14	2"

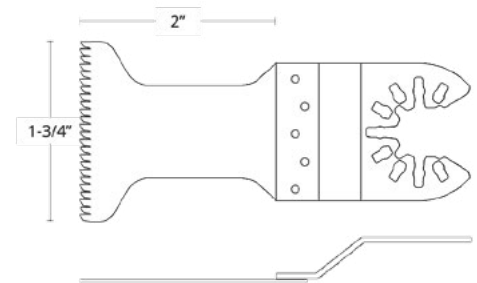

## 2-5/8" Japan Tooth Quick Release Saw Blade // AGGRESSIVE CUTS // Q009

Increase your linear cutting efficiency with this Japan tooth saw blade. Applicable for wide scale aggressive cutting of softer woods such as pines, spruces and fir. Clean linear cuts done quickly.

- The 2-5/8" precision ground double-row beveled tooth design facilitate wide scale aggressive cutting into wood, sheetrock and soft plastics
- The sharpened teeth on this blade will cut through laminates quickly without chipping
- Great for linear cutting of softwoods where maximum drive speeds can still produce a clean finish you'll love

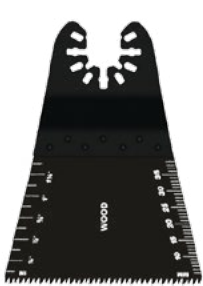

Blade width	Teeth per Inch	Plunge Depth
2-5/8" x 0.025" material thickness	14	1-9/16"



Clean Wood



Drywall



Plastics

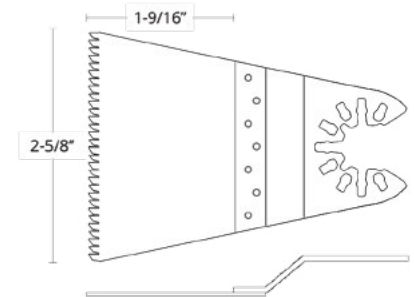

## 1-1/4" Fine Tooth Quick Release Saw Blade // FINE CUTS // Q003

This saw blade is designed for clean cutting of harder commercial grade woods such as oak, hickory and ash. Using this blade with a steady hand will give you a nice clean finish.

- Use this high carbon steel blade for clean flush cutting into hardwoods, plywood and particle boards
- The fine teeth on this blade make it excellent for controlled cutting of plastics, sheetrock, fiberglass and other non metallic materials



Blade width	Teeth per Inch	Plunge Depth
1-1/4" x 0.025" material thickness	18	1-5/8"



Clean Wood



Drywall



Plastics

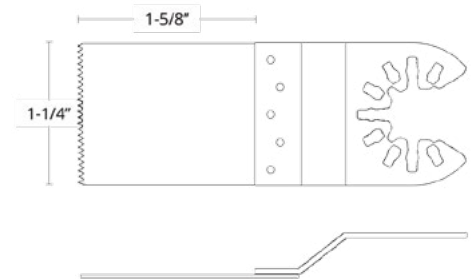

## 1-3/8" Quick Release Bi-Metal Hardwood Saw Blade // FINE CUTS // Q003bi

Here is a very effective hardwood saw blade that can also cut through nail embedded wood.

- By using M42 HSS for the cutting teeth we've significantly extended the service life of this blade
- Tough enough to cut through nails, this blade is specifically engineered to be an effective wood cutter
- Use this fine tooth blade for continuous cutting of hardwood, plywood and particle boards



Blade width	Teeth per Inch	Plunge Depth
1-3/8" x 0.025" material thickness	18	1-9/16"



Wood with Nails



Clean Wood



Drywall



Plastics

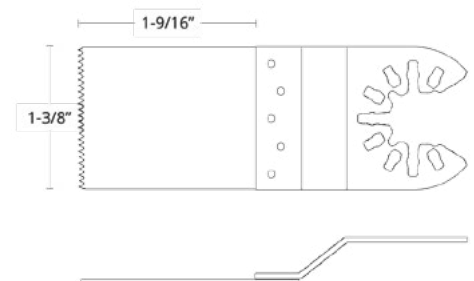



## 2-5/8" Fine Tooth Quick Release Saw Blade FINE CUTS **Q008**

Increase your linear cutting efficiency with this wide fine tooth saw blade. Use this blade for cutting harder grade woods.

- Designed for clean flush cutting into hardwoods, plywood and particle boards
- Excellent for controlled cutting applications of plastics, sheetrock, fiberglass and other non metallic materials
- Larger surface of this cutter makes it an excellent "shovel blade" for cutting and lifting old flooring coverings with ease

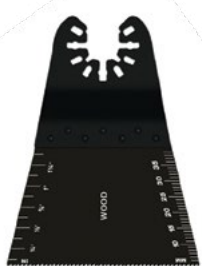

Blade width	Teeth per Inch	Plunge Depth
2-5/8" x 0.025" material thickness	18	1-9/16"

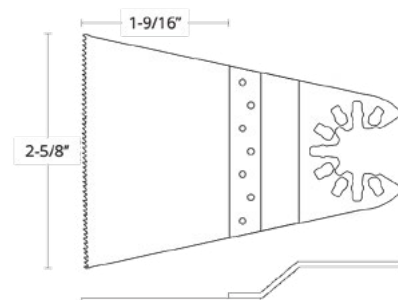

## 2-5/8" Quick Release Bi-Metal Hardwood Saw Blade FINE CUTS **Q008bi**

Use this wider hardwood saw blade for linear cuts through nail embedded wood.

- By using M42 HSS for the cutting teeth we've significantly extended the service life of this blade
- Tough enough to cut through nails, this wide blade is specifically engineered to be an effective wood cutter
- Use this fine tooth blade for continuous cutting of hardwood, plywood and particle boards



Blade width	Teeth per Inch	Plunge Depth
1" x 0.025" material thickness	18	1-9/16"

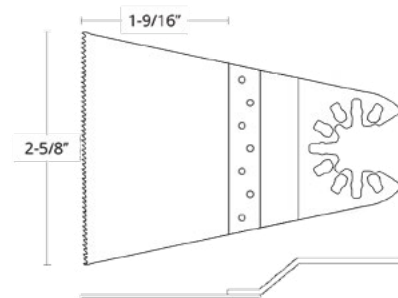

## 3/4" Fine Tooth Quick Release Saw Blade FINE CUTS **Q006HC**

This 3/4" wide saw blade is perfect for those smaller cut-outs. Use on wood, drywall and plastics.

- Use this high carbon steel blade for clean flush cutting into hardwoods, plywood and particle boards
- Fine teeth on this blade make it excellent for controlled cutting of plastics, sheetrock, fiberglass and other non metallic materials
- Sometimes there is no other way without this smaller cutter



Blade width	Teeth per Inch	Plunge Depth
3/4" x 0.025" material thickness	18	1-9/16"

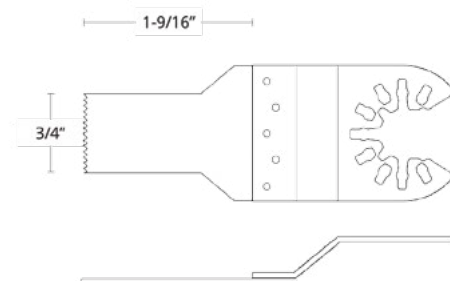

## 3/8" Fine Tooth Quick Release Saw Blade **Q005HC**

This 3/8" wide saw blade is perfect for those smaller cut-outs. Use on wood, drywall and plastics.

- Use this high carbon steel blade for clean flush cutting into hardwoods, plywood and particle boards
- Fine teeth on this blade make it excellent for controlled cutting of plastics, sheetrock, fiberglass and other non metallic materials
- Sometimes there is no other way without this smaller cutter



Blade width	Teeth per Inch	Plunge Depth
3/8" x 0.025" material thickness	18	1-9/16"



Clean Wood



Drywall



Plastics

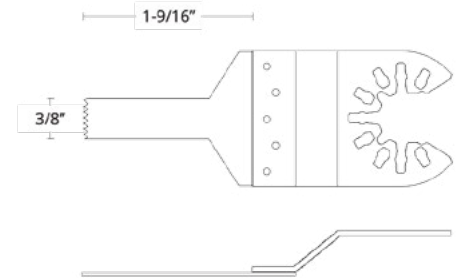

## Flush Cut Triangular Quick Release Carbide Rasp Q016

This triangular carbide rasp is excellent for coarse grinding of tile thin set mortar, hardened adhesives, masonry surfaces or concrete edges.

- Good for coarse grinding or rasping of thin set, masonry mortar and hardened adhesives
- Flush cut design and triangular shape will allow this rasp to be effective all the way into the corners
- Use this rasp to grind down concrete high spots or for any coarse removal of porous cement type materials



Blade width	Grit	Plunge Depth
3-1/8" tip-to-tip	30	N/A



Tile Grout



Plaster and Masonry

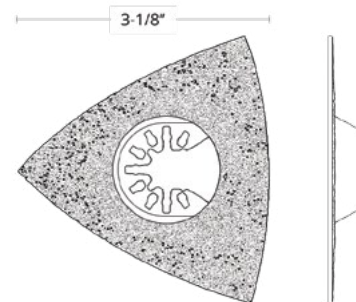

## Flush Cut Finger Quick Release Carbide Rasp Q017

This finger carbide rasp is essential for coarse removal of tile thin set mortar, hardened adhesives, masonry surfaces or concrete edges in tight spaces.

- Use this mini rasp for coarse material removal in tight areas
- With carbide grit on both sides, this rasp is also effective at penetrating removal of grout, thin sets or hardened adhesives
- Use this blade to rasp away concrete high spots or for localized flush grinding of porous cement type materials



Blade width	Grit	Plunge Depth
1-3/8" x 0.15" carbide grit thickness	30	N/A



Tile Grout



Plaster and Masonry

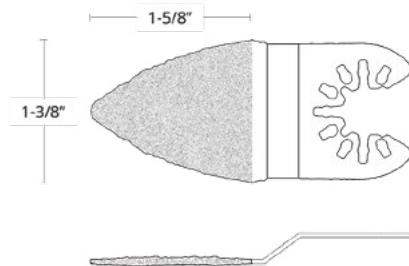

## 1-1/4" Flush Cut Quick Release Diamond Blade Q064

This diamond blade is great for controlled plunge cut situations. Cut into surfaces such as grout, Hardie board, concrete board and minor cut-outs into ceramic tile.

- Premium 1-1/4" width diamond-coated blade is great for flush-cutting away tile grout, mortar or thin-sets
- Great for making controlled plunge cuts, this blade will cleanly make slots, electric box openings or channels into concrete type surfaces
- Step-down design allows this diamond blade to cut cleanly flush with your desired surfaces all the way into the corners



Blade width	Grit	Plunge Depth
1-1/4" x 0.085" diamond grit thickness	30	1-1/4"



Tile Grout



Plaster and Masonry

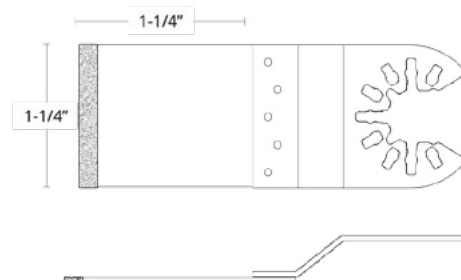



## 2-5/8" Segment Flush Cut Quick Release Diamond Blade **Q034**

Use this diamond blade as a plunge cutter for removing grout or use it for flush and undercutting situations.

- This premium blade is great for cutting tile grout, mortar or thin-sets
- The step-down design allows this diamond blade to cut flush with your desired surfaces all the way into the corners
- Choose this diamond blade for tile gaps from 0.070" and up



Blade width	Grit	Plunge Depth
2-5/8 x 0.07" diamond grit thickness	30	1-5/8



Tile Grout



Plaster and  
Masonry

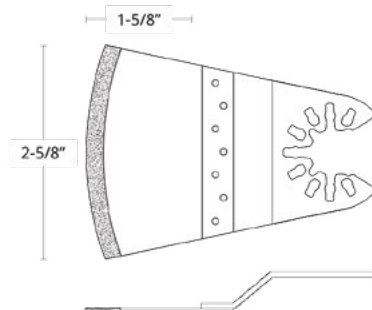

## Flat Knife Edge Quick Release Scraper // Q010

This stiff scraper is excellent for removing caulking or adhesives from a base surface. The flat profile facilitates plunge action material removal.

- Use this scraper to cut away adhesives, caulking, silicone or any other sealants away from a desired base surface
- The sharpened knife edge is also capable of cutting-up carpet, leather, linoleum and cardboard



Blade width	Teeth per Inch	Plunge Depth
2" x 0.032" material thickness	N/A	1-5/8"

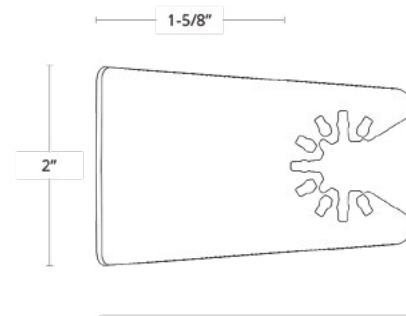

## Flush Cut Knife Edge Quick Release Scraper // Q011

This scraper is excellent for the controlled removal of caulking or adhesives. The flush cut design allows this blade to cleanly remove material away from a base surface.

- Use this scraper to clear away material build-up without harming most finishes
- The sharpened knife edge is also quite capable of cutting-up carpet, leather, linoleum or cardboard
- The step-down flush-cut profile design allows the operator to lay the blade flat on the working surface for consistent scraping results



Blade width	Teeth per Inch	Plunge Depth
2" x 0.03" material thickness	N/A	1"

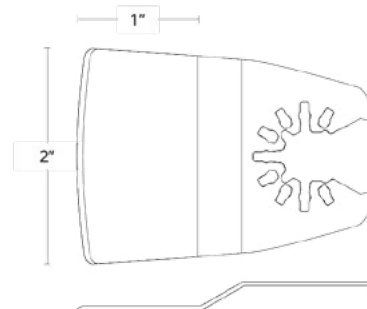

## Very Flexible Flat Knife Edge Quick Release Scraper // Q3021VF

This Scraper Blade turns tedious jobs into easy ones, it's perfect for separating material away from glass, plastic, metal or polished surfaces without damaging the base surface.

- This scraper blade is great for cutting away adhesives, caulking, silicone or any other material build-up away from a desired work surface
- Apply a little surface pressure to the blade's knife edge to effectively separate materials bonded by soft caulking



Blade width	Teeth per Inch	Plunge Depth
1-5/16" x 0.017" material thickness	N/A	1-7/8"



## Carpet Cutting Quick Release Hook Blade Q051

Use this hook knife to cut materials such as carpet, asphalt roofing shingles, flexible vinyl and fabrics.

- This sharpened double curved blade has an outward facing concave knife edge for push cutting and a hook blade for pull cutting
- Use this knife to cut flexible materials such as carpets, asphalt roofing shingles, fabrics and cardboard boxes
- Make straight, curved or complex line cuts without the wrist strains usually experienced with a hand held hook knife



Blade width	Teeth per Inch	Plunge Depth
1.6" x 0.045" material thickness	N/A	N/A

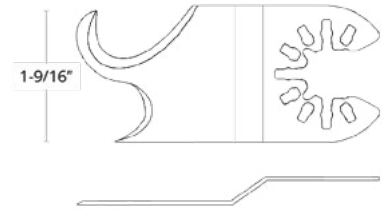

## Flush Cut Tapered Quick Release Sealant Cutter Q035

This Sealant Cutter is excellent for the removal of silicone caulking or soft adhesives. Having a full knife edge profile allows this blade to easily penetrate and cut pliable materials cleanly away from a base surface.

- The sharpened tapered edges on both sides of this blade are quite capable of separating most materials bonded by sealants
- The step-down flush-cut profile design allows the operator to lay the blade flat on a working surface for consistent controlled scraping



Blade width	Teeth per Inch	Plunge Depth
1-1/4" to 1/4" at tip 0.032" material thickness	N/A	2"

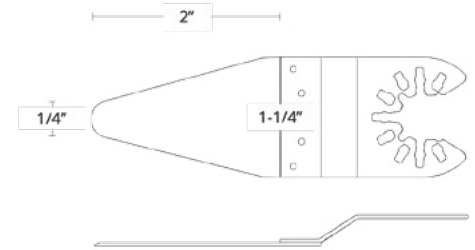

## 3 Inch Tapered Quick Release Sealant Cutter Q056

This flat stock tapered sealant cutter is excellent for penetrating removal of silicone caulking or soft adhesives in between base surfaces.

- This 3 inch long blade features sharp tapered edges on both sides for reaching into deep joints
- Use this tapered sealant cutter to remove adhesives, soft caulking, silicone or any other gummy material away from a desired base surface
- The flat stock profile of this blade is ideal for plunge removal of pliable caulking



Blade width	Teeth per Inch	Plunge Depth
1" to 1/4" at tip 0.045" material thickness	N/A	3"

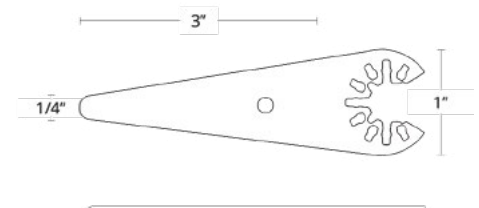

## Large Triangular Quick Release Sanding Pad Q119

This Bosch/Makita/Porter Cable & DeWalt matching size Velcro hook & loop sanding pad is also vented to accommodate vacuum dust extraction systems. This Pad will accept large vented or non-vented sanding sheets measuring 3-5/8 inch, tip-to-tip as well as our pre-cut Large Triangular Sanding Paper (Sku: Q93SP60 – 240).

- This sanding pad is a comparable match in size with the Bosch/Makita/Porter Cable & DeWalt factory size sanding pads
- Ideal for finishing work on most firm surfaces right into the corners for added versatility
- This premium hook and loop (Velcro) triangular sanding pad is perfect for sanding jobs utilizing quick attach hook & loop sandpaper

**Measurement  
tip-to-tip**

3-9/16" x 3-9/16"  
3/8" thickness

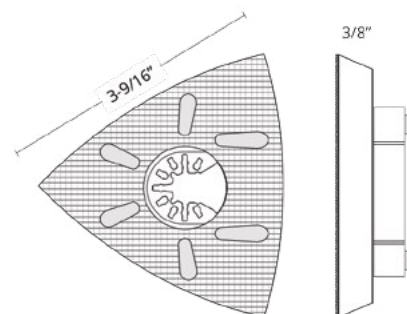

## Large Triangular Sanding Sheets (6 Pack) - Available in multiple grits

Our larger pre-cut sandpaper measure 3-5/8" tip-to-tip and have a Velcro backing that will match fit a factory Bosch/Makita/Porter Cable & DeWalt hook & loop sanding pad. Sandpaper meets or exceeds industry application standards.

- These larger pre-cut hook and loop (Velcro) sanding sheets are specifically designed for our Q119 sanding pads along with the Bosch/Makita/Porter Cable & DeWalt factory size pads
- These quick attach sandpaper sheets have a hook-and-loop backing for easy positioning and removal from matching oscillating sanding pads



Measurements tip-to-tip	Grit	Sku
3-5/8" x 3-5/8"	60	Q93SP60
3-5/8" x 3-5/8"	80	Q93SP80
3-5/8" x 3-5/8"	120	Q93SP120
3-5/8" x 3-5/8"	180	Q93SP180
3-5/8" x 3-5/8"	240	Q93SP240

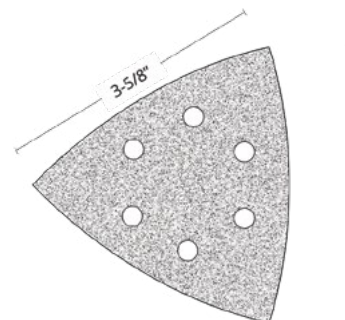

## Triangular Quick Release Sanding Pad Q019

This Velcro hook & loop sanding pad accommodates our multi-tool standard size triangular sanding sheets measuring 3-1/8 inch, tip-to-tip, (Sku: M025SP40 – 240).

- This popular size 'Velcro' pad turns your multi-tool into a sanding workhorse
- Ideal for finishing work on most surfaces all the way into the corners for added versatility
- This premium hook and loop (Velcro) triangular sanding pad is designed to utilize quick attach hook & loop triangular sanding sheets

**Measurement  
tip-to-tip**

3-1/8" x 3-1/8"  
3/8" thickness

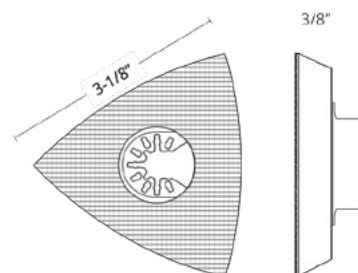



## Triangular Sanding Sheets (5 Pack) - Available in multiple grits

Our pre-cut sanding sheets have a Velcro backing and universally match fit most standard sized multi-tool hook & loop sanding pads. This product meets or exceeds industry application standards.

- These quick attach sandpaper sheets have a hook-and-loop backing for easy positioning and removal from a multi-tool triangular sanding pad
- These standard fit hook & loop sheets are for use with almost any brand multi-tool with a hook & loop sanding pad attachment



Measurements tip-to-tip	Grit	SKU
3-1/8" x 3-1/8"	40	M025SP40
3-1/8" x 3-1/8"	60	M025SP60
3-1/8" x 3-1/8"	80	M025SP80
3-1/8" x 3-1/8"	120	M025SP120
3-1/8" x 3-1/8"	180	M025SP180
3-1/8" x 3-1/8"	240	M025SP240

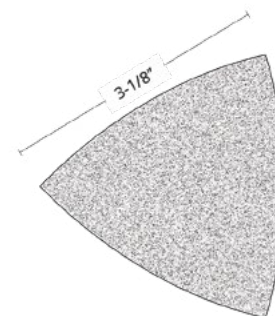

## Finger Sanding Pad Quick Release Q018

Use this mini Velcro hook & loop sanding pad get into in tight spaces. This small size pad accommodates our pre-cut Finger Sanding Sheets (SKU: M027SP40 - 240).

- The unique design lets you do multi-tool sanding in narrow hard-to-reach places such as channels, grooves, openings, rabbets, convex and hollow shapes for added versatility
- This premium hook and loop (Velcro) finger sanding pad is designed to utilize quick attach hook & loop "finger" sanding sheets



Pad Measurement
1-7/16" x 2"

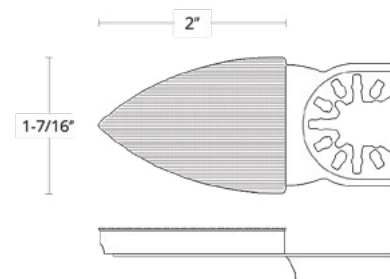

## Finger Sanding Sheets (5 Pack) - Available in multiple grits

These pre-cut sheets have a Velcro backing and match fit with our multi-tool Finger Sanding Pads. This product meets or exceeds common duty sanding standards.

- These quick attach sandpaper sheets have a hook-and-loop backing for easy positioning and removal from a multi-tool finger sanding pad
- These finger pad fit hook & loop sheets are for use with almost any brand multi-tool with a finger hook & loop sanding pad attachment



Measurements	Grit	SKU
1-7/16" x 2"	40	M027SP40
1-7/16" x 2"	60	M027SP60
1-7/16" x 2"	80	M027SP80
1-7/16" x 2"	120	M027SP120
1-7/16" x 2"	180	M027SP180
1-7/16" x 2"	240	M027SP240

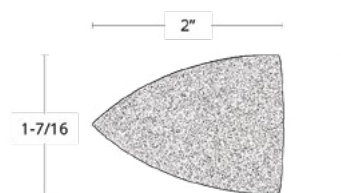

## Large Triangular Scouring Pad

**S419**

Our larger 3-5/8 inch tip-to-tip scouring sheets are perfect for cleaning applications on most surfaces.

- Made from soft non-woven nylon fibers, these sheets are designed to attach to your matching multi-tool sanding pad
- Great for scrubbing situations where you don't want scratching
- The red Velcro side attaches to your multi-tool sanding pad and the white side does the cleaning

Scouring side

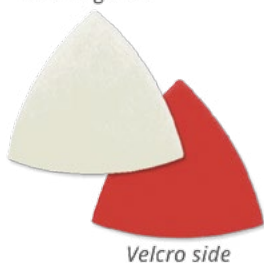
**Measurement**  
 tip-to-tip

3-5/8" x 3-5/8"  
 5/16" thickness

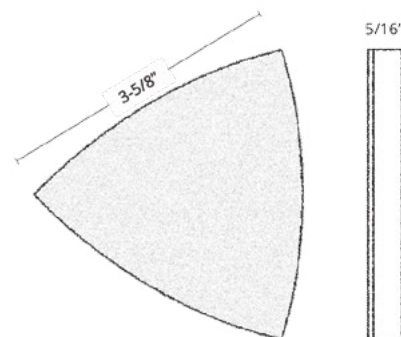

## Triangular Scouring Pad

**S319**

Our scouring sheets are perfect for cleaning applications on most surfaces indoor or out.

- These sheets are made of soft non-woven nylon fibers and are designed to attach onto your triangular multi-tool sanding pads
- Designed for light action scrubbing, these scouring sheets will not damage most surfaces and will compliment most cleaning solutions
- The red Velcro side attaches to your multi-tool sanding pad and the white side does the cleaning

Scouring side

**Measurement**  
 tip-to-tip

3-1/8" x 3-1/8"  
 5/16" thickness

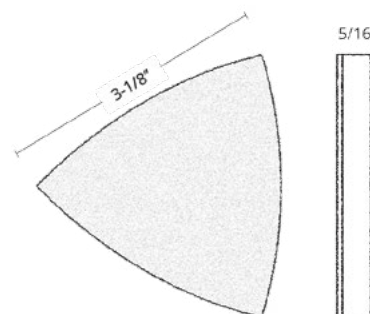

## C-Clip Adapter

**cclip**

This retainer is needed to secure our 'Quick Release' cutting blades and accessories onto Bosch or Dremel Multi-Tool models which utilize a Blade Change Lever clamping system.

- Bosch Multi-Tools utilizing a 'Blade Change Lever' will need to place this C-clip over our 'Quick Release' blade arbor to allow the machine's clamping prongs to secure 'Open Ended' style blades
- Dremel Multi-Max models utilizing a 'Blade Change Lever' will need to place this C-Clip over our 'Quick Release' blade arbor to allow the machine's clamping disc to secure 'Open Ended' style blades



### Compatible with:

Bosch MX30EC-31, Bosch MX30EC-21, Bosch MX30EK-33, Bosch MX30EK-35, Bosch MX30EL-37, Bosch MXH180BN, Bosch MXH180BL, Dremel Multi-Max MM40, Dremel Multi-Max MM45

## Quick Release 10 Piece Handyman Base Essentials Kit KIT10sxQR

Here is an essential group of blades that will allow you to handle the most common cutting jobs.

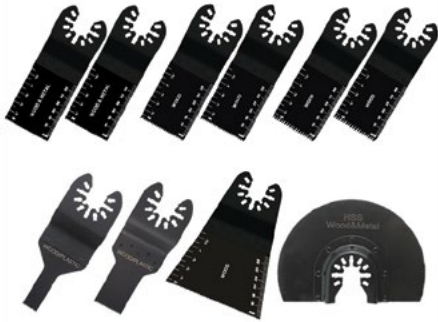

Includes	SKU
2 Pieces: 1-3/8" Bi-Metal Quick Release Saw Blade	Q001
2 Pieces: 1-1/4" Fine Tooth Quick Release Saw Blade	Q003
2 Pieces: 1-3/8" Japan Tooth Quick Release Saw Blade	Q004
1 Piece: 3/8" Fine Tooth Quick Release Saw Blade	Q005
1 Piece: 3/4" Fine Tooth Quick Release Saw Blade	Q006
1 Piece: 2-5/8" Fine Tooth Quick Release Saw Blade	Q008
1 Piece: 4.0" Flush Cut Segmented Circular Quick Release Saw Blade	Q122

## Quick Release 20 Piece Handyman Master Essentials Kit QRKIT20sx

Here is a comprehensive group of blades that will allow you to handle a broad range of cutting jobs.



Includes	SKU
3 Pieces: 1-3/8" Bi-Metal Universal Quick Release Saw Blade	Q001
2 Pieces: 1-1/8" Bi-Metal Quick Release Saw Blade	Q002
2 Pieces: 1-1/4" Fine Tooth Quick Release Saw Blade	Q003
2 Pieces: 1-3/8" Japan Tooth Quick Release Saw Blade	Q004
1 Piece: 1-3/4" Wide Bi-Metal Universal Saw Blade	Q005
1 Piece: 3/4" Fine Tooth Quick Release Saw Blade	Q006
2 Pieces: 2-5/8" Fine Tooth Quick Release Saw Blade	Q008
2 Pieces: 2-5/8" Japan Tooth Quick Release Saw Blade	Q009
1 Piece: Flush Cut Knife Edge Quick Release Scraper	Q011
1 Piece: Flush Cut Tapered Quick Release Sealant Cutter	Q035
2 Pieces: 4.0" circular HSS Saw Blade	Q122
1 Piece: Flexible Knife Edge Quick Release Flat Scraper	Q3021VF

## Quick Release 9 Piece Universal Bi-Metal Blade Trilogy BMTS9QR

Use this all bi-metal set of wood & metal cutting blades for demolition or construction jobs.



Includes	SKU
3 Pieces: 1-3/8" Bi-Metal Universal Quick Release Saw Blade	Q001
3 Pieces: 1-1/8" Bi-Metal Quick Release Saw Blade	Q002
3 Pieces: 1-3/4" Wide Bi-Metal Universal Saw Blade	Q045

## Quick Release 16 Piece Universal Bi-Metal Blade Tetralogy **BMTS16QR**

Use this all bi-metal set of wood & metal cutting blades for demolition or construction jobs.



Includes	SKU
4 Pieces: 1-3/8" Bi-Metal Universal Quick Release Saw Blade	Q001
4 Pieces: 1-1/8" Bi-Metal Quick Release Saw Blade	Q002
4 Pieces: 1-3/4" Wide Bi-Metal Universal Saw Blade	Q045
4 Pieces: 1-3/4" Wide Titanium Bi-Metal Universal Quick Release Saw Blade	Q450T

## Quick Release Blade Spring Special **QRBSS**

This 10 piece kit is popular with users who want a variety of plunge style saw blades for their multi-tool.



Includes	SKU
3 Pieces: 1-3/8" Bi-Metal Universal Saw Blade	Q001
2 Pieces: 1-1/4" Fine Tooth Quick Release Saw Blade	Q003
2 Pieces: 1-3/8" Japan Tooth Quick Release Saw Blade	Q004
1 Piece: 3/4" Fine Tooth Quick Release Saw Blade	Q006HC
1 Piece: 2-5/8" Fine Tooth Quick Release Saw Blade	Q008
1 Piece: 2-5/8" Japan Tooth Quick Release Saw Blade	Q009

## 9 Piece Japan Blade Quick Release Trilogy **QRJB9**

Here's a collection of our 3 most popular Japanese blade sizes. Use them for fast cutting of construction grade woods such as pine, spruce and fir.



Includes	SKU
3 Pieces: 2-5/8" Japan Tooth Quick Release Saw Blade	Q009
3 Pieces: 1-3/8" Japan Tooth Quick Release Saw Blade	Q004
3 Pieces: 1" Narrow Japan Tooth Quick Release Saw Blade	Q004-1TN

## 6 Piece Quick Release Tile Grout Essentials Kit *////////// QRKIT6tx*

This premium collection of diamond and carbide blade accessories will make short work of your tile grout removal projects.



Includes	SKU
1 Piece: 3-5/8" Flush Cut Diamond Quick Release Circular Blade	Q029TN
1 Piece: Flush Cut Triangular Quick Release Carbide Rasp	Q016
1 Piece: Flush Cut Finger Quick Release Carbide Rasp	Q017
1 Piece: 1-1/4" Flush Cut Quick Release Diamond Blade	Q064
1 Piece: Diamond Swing Blade Quick Release	Q031
1 Piece: 2-5/8" Segment Flush Cut Quick Release Diamond Blade	Q034

## 32 Piece Quick Release Basic Project Sanding Kit *////////// QRSPSK*

This kit contains the essential components needed for most multi-tool sanding projects. The included triangular hook & loop sanding pads and sanding sheets measure 3-1/8", tip-to-tip.



Includes	SKU
2 Pieces: Triangular Quick Release Sanding Pad	Q019

30 Sanding Sheets:

Grit	Triangular Sheets
60	15 pieces
120	10 pieces
180	5 pieces

## 32 Piece Quick Release Small Project Finger Sanding Kit *////////// QRSPFSK*

This kit contains the essential components needed for sanding in tight spaces using your multi-tool.



Includes	SKU
2 Pieces: Finger Sanding Pad	Q018

30 Sanding Sheets:

Grit	Finger Sheets
60	15 pieces
120	10 pieces
180	5 pieces

## 116 Piece Quick Release Sanding Essentials Kit *qrKITsandx*

This comprehensive kit is specifically designed to give DeWalt and Porter Cable multi-tool users an opportunity to experience the sanding versatility of their machines. The included vented Triangular Hook & Loop Sanding Pads and Sanding Sheets measure a large 3-9/16", tip-to-tip.

12 of each large grit / 10 of each finger grit



Includes		SKU
3 Pieces: Finger Sanding Pad		Q018
3 Pieces: Large Triangular Quick Release Sanding Pad		Q119
110 Sanding Sheets:		
Grit	Triangular Sheets	Finger Sheets
60	12 pieces	10 pieces
80	12 pieces	10 pieces
120	12 pieces	10 pieces
180	12 pieces	10 pieces
240	12 pieces	10 pieces

## 106 Piece Hyperlock Quick Release Sanding Kit *106qrkitsandx*

This comprehensive kit is designed to give Rockwell Sonicrafter Hyperlock multi-tool users the reserves needed to tackle a broad range of sanding jobs. The included triangular hook & loop sanding pads and sanding sheets measure, 3-1/8", tip-to-tip.

10 of each grit



Includes		SKU
3 Pieces: Finger Sanding Pad		Q018
3 Pieces: Triangular Sanding Pad		Q019
100 Sanding Sheets:		
Grit	Triangular Sheets	Finger Sheets
60	10 pieces	10 pieces
80	10 pieces	10 pieces
120	10 pieces	10 pieces
180	10 pieces	10 pieces
240	10 pieces	10 pieces

## ***Tips & Tricks***

### **Achieving Clean Cut-Lines using your Multi-Tool**

Do your multi-tool cuts look jagged and ugly? How can you make your cuts look cleaner with a machine you are basically using freehand?

#### **Here's what to do:**

Mark your cut line and with your multi-tool do a shallow score cut along the full length of that line. This initial cutting pass will serve as a tracking groove for your subsequent passes. Now on each new pass progressively work the blade deeper and deeper. Keep doing this until you cut all the way through the material.

This technique will give you the cleanest freehand cut possible using a multi-tool.

---

### **What blades are recommended for cutting tile grout, plaster, concrete board or Hardie board?**

If you've already tried to cut these abrasive materials with a regular saw blade you'll know that your cutting teeth will get completely worn down almost immediately. For these tough materials try using our carbide or diamond blades. Diamond blades are more expensive but will generally last longer than carbide blades. By comparison a standard carbide blade may remove up to 10 linear feet of tile grout where a diamond blade in the same situation, may remove up to 30 linear feet of grout.

---

### **A very simple guide to using the Speed Control dial on your Multi-tool**

This rule is easy to remember and gets you through 95% of all multi-tool situations. Set your multi-tool control dial to the **highest speed** for all cutting applications. It does not matter if you're sawing wood or metal, or if you're using a fine, coarse or Japan tooth blades, setting the speed dial to the highest number will be your most effective way to let the multi-tool do the cutting as you simply guide your machine.

The second part of this rule is to set the control dial to the **slowest speed** for all sanding. It does not matter what you're sanding or what size pad you're using, slowing the speed down will reduce critical heat buildup in the sanding sheets and pad. Reducing the heat buildup will extend the life of your pad's Velcro surface which is critical for holding the sanding sheets.



## ***Inventor Program***

At Multi-Fit Blades we regularly consult with independent inventors from around the world who present us with innovative new ideas for the oscillating tool industry. Several products shown in this catalog are the result of ideas submitted from inventors.

If you've invented or are currently developing an original application idea for oscillating multi-tools and would like to discuss the possibility of Multi-Fit Blades marketing or even producing this new product, please contact us and we will send you our [Inventor Disclosure Agreement](#).

This Inventor Program allows anyone regardless of their experience level to submit their idea or invention for a review by our experienced technicians. We will assess the marketability of new and original multi-tool accessory concepts with the understanding that we will commit to a design project that can justify a minimum production run of 10,000 units for our distribution and consumer networks. Typically our assessment process takes six months to a year to determine if an idea has profitability potential. Materials, prototypes, field testing and feasibility cost studies, are the investigations we take to ensure an idea successfully makes it to market.

We are specifically seeking unique ideas that directly enhance the feature capabilities of oscillating multi-tools. These new ideas could be for cutting, sanding or any other material removal situation where a process improvement would be welcomed by the industry.

Please be aware that most submitted ideas are dismissed upon receipt. In many cases these ideas cannot be cost effectively produced. Or sometimes an idea has already been submitted before and is being evaluated or was previously declined. We will only reply to multi-tool accessory idea submissions that interest us as being recognizably unique, innovating and potentially attractive to the marketplace.

For more information about our Product Development program, please email us at **[ideas@multifitblades.com](mailto:ideas@multifitblades.com)**





**Proudly serving our customers around the globe since 2010.**

Visit [MultiFitBlades.com](http://MultiFitBlades.com) to see even more blades and accessories to fit your multi-tool.



**Quick Release Arbor** VOL 2



**MULTIFITBLADES**  
oscillating tool blades and accessories



MultiFitBlades.com  
1-888-594-4442